

# Manheim Canada Arbitration Policy In-Lane and Online

January 2020 Revision 4.0

## I. General Policies

1. Fair and Reasonable Sale: Sales made at Manheim Canada auctions are intended to promote fair and reasonable treatment of both the Buyer and the Seller. If Manheim Canada (“Manheim”) determines that a sale is not fair and reasonable with respect to either party, or that a clerical or administrative error has occurred, the Seller and the Buyer agree that Manheim may, at its sole discretion, cancel or adjust the sale. Federal, Provincial, and local laws supersede these policies and local Manheim auction policies where applicable. This Manheim Canada Arbitration Policy (together with attached **Appendix 1**, this “Policy”) applies to all vehicles offered for sale, whether in-lane or online, at or through any Manheim auction located in Canada. Any arbitration conducted under this Policy is also subject to the Manheim Terms and Conditions, to be read consistently with this Policy.
2. Seller Disclosure Standards: Manheim requires Sellers to make disclosures in accordance with the disclosure standards attached as **Appendix 1**. Appendix 1 describes the minimum required disclosures and is not intended to limit the Seller’s ability to make any additional disclosures it deems prudent.
3. Manheim Selling Channels Defined: The selling channels are defined as follows:
  1. In-Lane: All purchases made by a bidder on auction location property. Vehicle purchases in an online event sale by bidders at an auction location will be considered In-Lane sales.
  2. Online: All purchases made by a remote bidder via the Internet. Due to the differences associated with purchasing through online channels, such as the inability of the Buyer to view the vehicle, additional time parameters and damage disclosure requirements for arbitration have been included in this Policy.
  3. Online Without Vehicle Condition Information: All purchases made through online channels without a written condition report, inspection, or a disclosure as to the vehicle's condition are considered Online Without Vehicle Condition Information.
4. Manheim’s Role in the Sale:
  - All representations and guaranties stated by the Seller are those of the Seller only. Manheim hereby expressly disclaims any and all representations, warranties, and guarantees of every kind, whether express or implied, as to any vehicle sold or offered for sale, including, without limitation, the vehicle description, condition, structural integrity, equipment, warranties, service

policy, ownership status/accuracy, liens/encumbrances, or odometer reading or disclosure.

- Although a beneficiary of certain rights in the bill of sale, Manheim is not a party to the contract of the sale. The sales transaction is between the Seller and the Buyer only. The Seller is required to give an accurate odometer disclosure in connection with any auction sale in accordance with the Motor Vehicle Dealers Act of 2002 and any other applicable laws. Manheim is not responsible for the accuracy of odometer readings, odometer statements, or damage disclosure statements.
  - All vehicles bought or sold on the premises must be processed through the auction office, including Off-Block Sales as described below in Section 6. Failure to do so will result in suspension of trading privileges at Manheim.
5. Unsafe Vehicles: Manheim reserves the right to reject for sale any vehicle Manheim considers, in its sole discretion, to be unsafe.
6. Off-Block Sales:
- Any sale in which the auctioneer does not state the selling price of the vehicle or "sell under the hammer" is considered an Off-Block Sale.
  - All Off-Block Sales are conditional until the Buyer signs the sale contract or appropriate document for the vehicle signifying he or she has inspected and accepted the vehicle. Until the appropriate document is signed, the sale is not binding on either party.
  - Off-Block Sales must be processed through the auction office. Vehicles sold after crossing the block are still subject to the announced conditions noted on the Manheim sales receipt/contract and the terms described in Section III below (Arbitration Guidelines) and **Appendix 1**.
  - As with all auction units, Buyers are cautioned to inspect Off-Block Sale vehicles very carefully and verify announced conditions before purchasing.
7. VIN Policies:
- All vehicles consigned must have a public Vehicle Identification Number ("VIN") plate attached to the vehicle. Manheim reserves the right to refuse the sale of any vehicle in which the VIN plate appears to be missing or altered in any way.
  - The Seller guarantees VIN plates and years on any vehicle up to twenty (20) model years old with the exception of trailers, RVs, and watercraft, on which the VIN plates and years are guaranteed up to ten (10) model years.
8. Right of Review: Manheim reserves the right to review any audio/video documentation of a sale to verify its accuracy and fairness.
9. Official Inspections: All vehicles registered and/or sold at any Manheim auction are subject to inspection, with or without prior notice, by Manheim, the RCMP, Provincial

Police, National Auto Theft Bureau, Local Police Authorities, and any other governmental or quasi-governmental agency with apparent jurisdiction.

## II. Sale-Light / Video Display Systems: In-Lane and Online Simulcast Only

1. Auction Sale-Light/Video Display System: Manheim auctions have a light/video display system to describe the condition and/or announcements related to vehicles sold through in-lane and online Simulcast selling channels. The sale-light/video display system includes the following designations, which affect the availability of arbitration with respect to the vehicle. The following designations are the most commonly-used, but they are not exclusive and are not guaranteed to be used at each sale. In some cases, a vehicle may sell under multiple light designations:
  - Green Light - "Ride and Drive": A green light signals that the vehicle is guaranteed under the conditions outlined in Section III (Arbitration Guidelines) and **Appendix 1**, except for specific announcements made prior to the sale.
  - Yellow Light - "Announcements": A yellow light is an indication to the Buyer that the Seller or auctioneer has made announcements that qualify and/or clarify the condition of the vehicle or its equipment and limit arbitration.
  - Red Light - "AS-IS": Vehicles selling under a red light may not be arbitrated for certain conditions, as detailed below in Section III. Where applicable, Federal, Provincial, and local laws may supersede this Policy (including **Appendix 1**) and local auction policies with respect to AS-IS vehicles.
  - Blue Light – "Title Absent" and/or "Out of Province" (Alberta only): A blue light means that the vehicle is sold with a bill of sale only and that there is no ownership present to transfer. In Alberta, the blue light may also signify an "Out of Province" vehicle.

## III. Arbitration Guidelines

Defects, conditions, or discrepancies described in this Policy may be eligible for arbitration if: (1) the defect, condition, or discrepancy was not disclosed or announced at the time of sale, despite a requirement to do so under this Policy; and (2) the request for arbitration is made within the arbitration period described in this Policy. To be arbitrated vehicles must be returned to Manheim in the same or better condition than when purchased.

The buyer is required to pick up the vehicle within five (5) business days of the date of purchase. Failure to remove vehicles within this timeframe can result in loss of arbitration rights.

The following terms apply:

1. Arbitration Period: The attached **Appendix 1** describes the time period during which the Buyer may request arbitration for specified conditions and defects. The following terms apply:

- The Buyer may order a post-sale inspection (“PSI”) at any time before the close of business hours on sale day at the auction where the vehicle was purchased. If the Buyer orders a PSI, the applicable arbitration period will be extended until the PSI has been completed and Manheim has communicated the results to the Buyer. For online purchases, vehicle must be taken to the closest available Manheim Auction to preform PSI services.
  - Sale day is counted as the first day of the arbitration period.
  - Arbitration must be requested on or before the last day of the applicable arbitration period and before closing time at the auction where the sale occurred.
2. Process: Manheim will inspect only the defect(s), conditions, or discrepancies described in the initial arbitration request and only if covered by this Policy. Each sale is allowed one chance at arbitration. If a price adjustment is made and accepted, the vehicle becomes AS-IS property of the Buyer and is not subject to any further arbitration. The decision of the Manheim arbitrator is final and binding on both the Buyer and the Seller.
3. Arbitration Fees: Manheim reserves the right to assess an arbitration fee to the Buyer in the event the Manheim arbitrator finds, in his or her sole discretion, that the arbitration request is without merit. Manheim reserves the right to assess an arbitration fee to the Seller in the event that the Manheim arbitrator finds, in his or her sole discretion, that the Seller has not met all of the disclosure obligations set out in this Policy with respect to the arbitration request. The fee schedule in use at the auction where the sale occurred will determine the amount of any fees imposed pursuant to this paragraph. Any fees assessed to either party pursuant to this paragraph are in addition to any charges associated with the arbitration procedure, such as inspection fees at a third party franchise or specialty shop or transportation costs to and from a garage, etc., and any awarded price adjustment. Each arbitration request must be properly documented in writing by the Buyer.
4. Exclusions: The following exclusions apply in addition to those set out in **Appendix 1**:
- Visible or Announced Conditions: Manheim will not arbitrate announced conditions with respect to any sale and will not arbitrate visible defects except as provided below with respect to online sales.
  - Vehicle Histories: Manheim is not bound by information that appears in any vehicle history report (i.e. Carfax, AutoCheck, Carproof, etc.), and the Buyer has no arbitration right based solely on data contained in any such report. In connection with an arbitration, Manheim may, in its sole discretion, obtain and use information found in vehicle history reports.
  - Aged Vehicles: Vehicles are not subject to arbitration if they exceed twenty (20) model years in age. Trailers, RVs, and watercraft cannot be arbitrated if they exceed ten (10) model years.
  - Nonstandard and Modified Vehicles: Kit vehicles, homemade vehicles, or modified vehicles are sold AS-IS and cannot be arbitrated for odometer, frame, VIN plates, warranty books, or model year.

- Noise and Inherent Conditions: The Buyer has no arbitration rights based on noises or conditions that are inherent or typical to a particular model or manufacturer, unless deemed "excessive" by the arbitrator, in his or her sole discretion, with respect to non-warranty items. OEM dealer warranty guidelines may be used where applicable to determine whether the condition is excessive.
  - As-Is: Any in-lane or online vehicle sold AS-IS is NOT subject to arbitration for any of the following conditions: (i) Major Repair , Warranty Cancelled, Sludged Engine, Alternate Fuel or Conversion, and Non-Original Engine (each as described in **Appendix 1**); (ii) Vehicle not equipped with air conditioning; and (iii) Paintwork (current model year or newer). The local auction policy governs the arbitration of AS-IS vehicles for selling price, model year, and mileage and applicability of the Arbitration Dollar Threshold (described in **Appendix 1**).
5. Terms Specific to Online Selling Channels: The following terms apply only to online selling channels. Unless otherwise specified, terms set forth elsewhere in this Policy also apply to online selling channels.
- Sellers' Duties: Sellers who sell through any online selling channel (as described above) are responsible for making all disclosures required by this Policy **regardless of**: (1) the sale light/video display designation (if any) applied to the vehicle at the time of sale; and (2) whether the defect or condition is visible. As with all sales, Manheim will not arbitrate conditions announced, either orally or in writing, at the time of sale. Any images used at the time of sale must show the actual vehicle unless the Seller makes it known, through a proper disclosure, that the actual vehicle is not shown.
  - Buyers' Duties:
    1. Knowledge of Process: The Buyer is responsible for understanding the Online Bidding, Proxy Bidding, and Buy Now procedures for online buying channels.
    2. Vehicle Inspection: Buyers who purchase through any online selling channel are encouraged to have a Post Sale Inspection ("PSI") done on all purchased vehicles. For online purchases, vehicle must be taken to the closest available Manheim Auction to preform PSI services. Regardless of whether a PSI is done, it is the Buyer's sole responsibility to inspect each vehicle purchased immediately upon obtaining possession of the vehicle, whether by delivery to the Buyer's location or pick-up at the auction location. The Buyer is solely responsible for verifying the Seller's representations, including the odometer reading, and notifying Manheim of any discrepancies or other issues within the applicable arbitration period set out in this Policy (or, if a PSI is ordered, within the extended time period provided above).
6. Sellers' Responsibility for Vehicle Descriptions/Disclosures: The Seller will be held responsible for the accuracy and completeness of all representations, disclosures, and descriptions regarding any vehicle offered for sale by or on behalf of the Seller. This includes, without limitation: (a) any vehicle sale-light/video display designations,

announcements and/or guarantees offered at the time of sale; (b) all images, text representations, handouts, catalogues, vehicle markings, and oral or written statements made by the auctioneer, the Seller, or the Seller's designee or agent with regard to the vehicle; (c) third-party condition reports made available by the Seller, or the Seller's designee or agent; and (d) the vehicle's year, make, model, odometer reading, and equipment. The Seller understands that the sale light/video display designation is a binding arbitration representation by the Seller and that Seller is therefore responsible for ensuring that Seller's vehicles sell under the correct designation.

7. Seller's Reimbursement Obligation: Manheim reserves the right, in its sole discretion, to require the Seller to reimburse the Buyer for any reasonable, documented expenses incurred by the Buyer (excluding profit, commissions, and detail charges) on vehicles successfully arbitrated. Expense reimbursements will be at the sole discretion of Manheim and will, at times, be limited to reasonable and documented expenses and transportation only.
8. Buyer Responsibilities and Liabilities:
  - It is the Buyer's responsibility to satisfy itself with a vehicle's condition and to watch sale-lights/video displays (if any) and listen to announced conditions before placing bids. Once the vehicle is sold, the Buyer should check the auction contract to confirm the vehicle price and announcements are correct before legibly printing and signing (or electronically signing) the auction contract. The Buyer should thoroughly check and, if possible, test-drive every vehicle purchased. If there is any problem, the Buyer must request arbitration within the applicable arbitration time limit set forth in this Policy. The Buyer assumes full responsibility for mechanical or electrical failure once the arbitration period is over.
  - The Buyer agrees to be liable for any and all work done to a vehicle prior to the Buyer's becoming aware of the defect or condition that is the subject of the arbitration request and prior to the Buyer's returning the vehicle to Manheim, except to the extent that Manheim orders the Seller to reimburse the Buyer pursuant to Section III(7) above. An arbitrated vehicle must be returned in a timely manner consistent with Auction direction.
  - The Buyer is financially responsible for any pending sale until arbitration is final.
  - The Buyer, Buyer's designee, or Buyer's agent (e.g. transporter or driver) should note any obvious damage on the gate release prior to removing the vehicle from the auction or facilitation service provider's location. Buyer may not arbitrate any obvious damage not identified on the gate release or the condition report once the vehicle is removed from the auction or facilitation service provider's location.
1. Notice Regarding Claims: The Buyer shall not surrender possession of the vehicle to any claimant, except as required by legal process or as directed by Manheim, nor shall Buyer voluntarily pay or acknowledge the validity of any claim, without the prior approval of Manheim. Time is of the essence. Any failure of the Buyer, after becoming aware of any

such claim, to notify Manheim in a timely manner or failure of the Buyer to cooperate in defending any such claim shall relieve Manheim of any liability under this Policy.

2. Payment in Arbitration: Seller will not be paid for any vehicle in arbitration until arbitration is settled and a corrected bill of sale has been issued. For sales voided through arbitration after the Seller has been paid, Seller is required to promptly return to Manheim the sales proceeds, expense reimbursement (if any), and any other amounts the arbitrator orders paid.
3. Return Process: A vehicle is not considered returned until received, inspected, and approved for return by Manheim. Any vehicle returned must be in the same or better condition as when sold. Any vehicles delivered to and left on auction premises without Manheim's approval remain the sole responsibility of the Buyer, and Buyer assumes all risk of loss.
4. Charge for Excessive Mileage: Manheim reserves the right, in its sole discretion, to impose a charge for excessive mileage on a returned vehicle.
5. Inoperable Odometer: If the Buyer requests arbitration for an inoperable odometer, the odometer reading must be the same as when the vehicle left the auction location.

#### **IV. Registration Arbitration Policy**

1. Seller Registration Responsibilities & Guarantee:
  - All registrations submitted by the Seller must include the Seller's company name on the ownership certificate or on a properly executed reassignment form. Unless otherwise announced or disclosed at the time of sale, the Seller guarantees, for a period of forty-eight (48) months beginning on the date of sale, marketable ownership free and clear of: (a) all liens and encumbrances; and (b) any "ownership brand" on the current or any previous ownership certificate that is required to be disclosed under this Policy or any applicable Federal, Provincial, or local law. Seller's liability under this ownership guarantee shall never exceed the auction sale price of the vehicle, not including any applicable fees or taxes, and this amount shall be reduced by two percent (2%) per month for depreciation following the sale date. All liability under this ownership guarantee shall expire and terminate 48 months after the auction sale date. Manheim will not be responsible for any expenses incurred on vehicles returned for late ownership.
  - The Seller warrants, represents, and guarantees to the Buyer and Manheim that Seller has and will convey a certificate of ownership, properly executed, valid in the province where the transaction is occurring, and clear of all liens and encumbrances and that he or she will warrant and defend the ownership against the claims and demands of all persons whatsoever.
2. Manheim's Right to Remediate Clerical Error: If an ownership problem occurs due to a clerical or coding error, or incomplete documentation, Manheim shall be given a reasonable time after receiving notice to have the error corrected.

3. Buyer's Registration Claim Notice to Auction: Whenever any claim is made by any person against the ownership of a vehicle, whether by suit or otherwise, the Buyer, after becoming aware of said claim, shall immediately notify Manheim, provide Manheim with full particulars of the claim, and cooperate fully with Manheim in defending any legal action and/or in taking other steps requested by Manheim to minimize possible loss.
4. Registration Assignment: Ownership must be reassigned directly to Buyer. No ownership assigned directly to Manheim will be accepted.
5. Payment after Registration Receipt: Seller will not be paid for vehicles until a transferable ownership is received.
6. Non-Registered Vehicles Rule:
  - Manheim accepts no responsibility for non-registered vehicles sold without an ownership. Seller must announce the vehicle is being sold with a bill of sale only and that there is no ownership to transfer.
  - All non-registered vehicles and equipment will be sold AS-IS.
7. Unacceptable Ownership Documents:
  - Applications or other documents related to a duplicate ownership will not be accepted (unless announced as such or if allowed by the appropriate jurisdiction).
  - Foreign titles, such as United States titles, are unacceptable.
8. Vehicle Registration Timelines:
  - It is the Seller's responsibility to ensure that Manheim receives the ownership of each vehicle sold within seven (7) calendar days after the sale. The day of the sale is counted as day one (1).
  - After the seven-day calendar day period, it is the Buyer's option to return the vehicle or wait a reasonable period of time for the ownership.
  - Neither Manheim nor the Seller shall be liable for any vehicle transfer or repair made by the Buyer before the Buyer receives the vehicle ownership. If the ownership has been mailed or otherwise delivered to Buyer, Buyer may not return vehicle. Buyer is required to notify Manheim, in a timely manner consistent with the policy of the auction where the sale occurred, that a vehicle will be returned. If valid, negotiable ownership is presented within the auction policy notice period, the Buyer may not return the vehicle for late ownership.
  - If, after ninety (90) calendar days, the Seller has not produced valid, negotiable ownership, and the Buyer has not returned the vehicle, the limited ownership guarantee shall no longer apply, and Manheim shall have no duty to produce the certificate of ownership to the Buyer and shall have no duty to pay the Seller.
  - Seller Additional Fees:



1. If a vehicle is returned pursuant to this Section IV(8), Seller will be responsible for the buy fee plus reasonable and documented expenses for transportation of the vehicle to and from the Buyer's location to Manheim. If the policy of the auction where the sale occurred permits, the Seller may also be charged for any other reasonable expenses incurred by the Buyer.
2. Ownerships received by Manheim more than seven (7) calendar days after the sale may be subject to a late fee. All expenses Manheim incurs in obtaining the ownership will be charged to the Seller.
9. Indemnification of Manheim: In regard to defects in ownership, and in any matter relating to odometer mileage, odometer statements, or damage disclosure statements, the Seller and the Buyer agree to indemnify and hold harmless Manheim from any liability, loss costs, damage, or expenses, including attorney's fees which may arise either directly or indirectly from the sale and purchase of the consigned vehicle, including, but not limited to, ownership services provided.
10. Buyer Delivery Responsibility: Manheim will not be responsible for ownerships mailed from Manheim and not received by the Buyer. The Buyer has the option of alternative delivery methods for a fee.
11. Seller Odometer Disclosures: All vehicles sold in Canada require an odometer disclosure.

## **V. Grey Market & U.S. Vehicles**

1. Eligible Vehicles: Only vehicles made in North America for use in (i) Canada or (ii) the U.S. and properly converted to Canadian specifications can be sold, and the Seller must give appropriate disclosures as described in **Appendix 1**. Manheim will not accept, and Sellers may not offer for sale, any other Grey Market vehicles, including vehicles of European manufacture.
2. Seller Responsibilities: Seller must inform Manheim that a vehicle has U.S. history at the time of registration and must disclose that to the Buyer in writing as an announced condition on the contract.
3. Proper Conversion: If a vehicle was manufactured in the U.S. for the U.S. Market, the Seller is required to ensure the proper RIV process has been completed, and the vehicle must have a valid Canadian ownership. Manheim may order a vehicle history report with respect to such vehicles and charge the Seller a fee for this service.
4. Compliance with Standards: Grey Market Vehicles will not be accepted for sale unless they meet ALL applicable Federal/Provincial D.O.T. / E.P.A. Mandated Guidelines. The Seller must provide documentation of compliance with all such standards.

### **APPENDIX 1**

## SELLER DISCLOSURE STANDARDS (CANADA)

### A. NAAA Seller Disclosure Standards



# Seller Disclosure Standards CANADA

January 2017

*A Seller will build confidence in its product and credibility with Buyers by disclosing all material facts about the history and condition of the vehicle offered for sale. A Seller who consigns a vehicle for sale at a participating Canadian NAAA member auction (the "Auction") is required to disclose the information listed below. The list is not intended to be exhaustive. As vehicles and our industry change, the disclosure obligations required of Sellers may similarly change. Accordingly, the Auction reserves the right to require the disclosure of other information not specifically listed below.*

Declaration	Explanation	Arbitration Period
ABS Defective	The Seller must disclose if the anti-lock braking system is not operational (if equipped). Arbitration is only available for repairs over the applicable Arbitration Dollar Threshold (see Major Repair).	Regular
Accident Repair \$ _____	The Seller must declare a Vehicle to be Accident Repaired if the total cost to fix damage caused by a single incident was \$3,000 or more (\$2,000 cumulative incidents in British Columbia). <b>The Accident Repair declaration must be made regardless of whether the damage was caused by collision, accident, weather or by some other incident.</b> If the dollar value of the repair is known, it must be declared. If the dollar value of the Accident Repair is not known but estimate data is available, the estimate data should be disclosed. Although not required, if the Seller chooses to declare an accident repair under \$3,000 (\$2,000 cumulative in B.C.), it may do so separately as an additional disclosure. Arbitration is not allowed for repairs under \$3,000 (\$2,000 cumulative in British Columbia).	Regular
Adjacent Panels Replaced	The Seller must declare if two or more adjacent panels (excluding bumper panels) have been replaced on a vehicle. Please note: If the panels were replaced due to an accident or other incident, depending on the cost of the repairs, it may also be necessary for the Seller to make the Accident Repair declaration.	Regular
Air Bags Missing/Defective	The Seller must disclose if the vehicle's airbags are missing or not operational. Arbitration is only available for repairs that exceed the Arbitration Dollar Threshold (see <i>Major Repair</i> ).	Regular
Alternate Fuel or Conversion	The Seller must disclose if the vehicle uses propane or natural gas, or at any time had a propane or natural gas fuel system.	Regular
Excessive Rust	The Seller must disclose if the vehicle suffers from excessive rust. Rust is considered to be excessive when the location or quantity of the rust affects the structural integrity of the vehicle, e.g. the frame or any structural component is perforated by rust.	Regular
Fire Damage	The Seller must disclose if the vehicle has been damaged by fire.	Extended
Flood Damage	The Seller must declare a vehicle as Flood Damaged when: <ul style="list-style-type: none"> <li>• water or other liquid has penetrated the vehicle to the level of the floor boards or higher; or</li> <li>• if any of the following components have been damaged due to immersion: <ul style="list-style-type: none"> <li>➢ Front or rear lighting or wiring harnesses</li> <li>➢ Engine and its major components</li> </ul> </li> </ul>	Extended

Declaration	Explanation	Arbitration Period						
	<ul style="list-style-type: none"> <li>➤ Transmission and differential</li> <li>➤ Dash instrument panel and wiring</li> <li>➤ Passenger seat cushions</li> <li>➤ Power seat or window motor</li> <li>➤ Major sound system components</li> </ul>							
Grey Market*	The Seller must declare if the vehicle was ever registered in a country other than the United States or Canada in the past 36 months or manufactured not in compliance with North American standards. All Grey market vehicles offered for sale must include a CarProof Verified vehicle history report, or equivalent.	Regular						
Incorrect Vehicle Marking	The Seller must disclose if any logo, badge, decal, emblem, ornament or similar markings on the vehicle do not match the make, model or series of the vehicle.	Regular						
Irreparable	Regardless of whether the title has been branded, the Seller must disclose if the vehicle is not capable of being repaired for roadworthy operation and may only be used for parts or scrap. Irreparable vehicles are assumed to also be Total Loss vehicles and thus the Total Loss declaration does not need to be made.	Extended						
Km _____	If the odometer reading is accurate, the Seller must disclose the distance the vehicle has travelled as indicated on the odometer. Minor odometer discrepancies of 3,000 km or 5% (whichever is less) are not subject to arbitration.	Extended						
Major Repair _____ (details)	<p>Where the cost of repair exceeds the Arbitration Dollar Threshold, the Seller must disclose: (a) if a Major Component of the vehicle is defective or not operational; (b) body damage (including hail damage); (c) non-mechanical or non-electrical defects (excluding Wearable Items and Normal Exterior Wear and Tear); and (d) listed accessories that are not working (e.g. cruise control, lane departure warning).</p> <p><b>Arbitration Dollar Threshold:</b></p> <table border="1"> <thead> <tr> <th>Vehicle Sale Price</th> <th>Arbitration Dollar Threshold</th> </tr> </thead> <tbody> <tr> <td>Under \$40,000</td> <td>\$750</td> </tr> <tr> <td>\$40,000 and over</td> <td>2% of vehicle sale price</td> </tr> </tbody> </table> <p>The Arbitration Dollar Threshold is calculated before taxes, on a non-cumulative basis and in accordance with standard Mitchell warranty rates.</p> <p>Major Components include:</p> <ul style="list-style-type: none"> <li>➤ Engine</li> <li>➤ Transmission</li> <li>➤ Power train</li> <li>➤ Sub-frame</li> <li>➤ Electrical/Air ride suspension</li> <li>➤ Computer equipment</li> <li>➤ Fuel operating system</li> <li>➤ Electrical system</li> <li>➤ Emissions system</li> <li>➤ Anti-lock braking system</li> </ul> <p><i>Wearable Items and Normal Exterior Wear and Tear</i> are not subject to arbitration.</p> <p><b>Wearable Items</b> are parts of the Vehicle that the manufacturer recognizes the need for replacement or adjustment during the expected life of the vehicle. These items are normally identified in the Owner's Manual for routine check and replacement and include but are not limited to: wipers, brake pads, shoes, rotors, calipers, belts, hoses, lubricants, fluids, timing belts, bulbs, filters, manual clutch, shocks and struts.</p> <p><b>Normal Exterior Wear and Tear</b> means damage that would be considered normal wear and tear given the distance travelled and age of the Vehicle and is not easily seen, such as scratches that do not break the paint, minor nicks, cuts and/or scuffs.</p>	Vehicle Sale Price	Arbitration Dollar Threshold	Under \$40,000	\$750	\$40,000 and over	2% of vehicle sale price	Regular
Vehicle Sale Price	Arbitration Dollar Threshold							
Under \$40,000	\$750							
\$40,000 and over	2% of vehicle sale price							

Declaration	Explanation	Arbitration Period
Manufacturer Repurchase <u>(details)</u>	The Seller must disclose if the motor vehicle was repurchased by the manufacturer under the Canadian Motor Vehicle Arbitration Plan or under the laws of any jurisdiction including but not limited to U.S. lemon laws. If the reasons for, date and/or jurisdiction of the repurchase are known, they should be disclosed.	Regular
Material Variation from Production Specs	The Seller must disclose if the vehicle varies materially from the original manufacturer's specifications.	Regular
Odo 5 digit	The Seller must disclose if the odometer is a 5 digit odometer with over 100,000 miles or kilometers.	Regular
Odo Broken/Faulty	The Seller must disclose if the odometer of the vehicle is broken or faulty, i.e. not accurately tracking distance driven.	Regular
Odo in Miles	The Seller must disclose if the odometer is in miles.	Regular
Odo Replaced	The Seller must disclose if the odometer has been replaced.	Extended
Odo Roll back	The Seller must disclose if the odometer has been rolled back.	Extended
Odo Unreadable	The Seller must declare the odometer to be unreadable if it is accurately tracking distance driven but cannot be read due to pixel damage, because the vehicle cannot be started to obtain an odometer reading, or similar reasons.	Regular
Out of Province*	<p>If the province of the last registration (or equivalent) to a retail customer is different than the jurisdiction from which the Vehicle is currently being sold, the Vehicle must be declared an out of province Vehicle and the Seller must identify the last province in which the Vehicle was registered (or equivalent) to a retail customer.</p> <p>For vehicles sold in Ontario only: A vehicle remains an out of province vehicle and must be so declared, if it was previously registered (or equivalent) to a retail customer in another province and has been registered in Ontario for less than 7 consecutive years.</p> <p>The Seller must declare all of the provinces in which the vehicle was previously registered.</p>	Regular
Previous Daily Rental	The Seller must disclose if the Vehicle was previously used as a daily rental vehicle at any time in the previous 24 months.	Regular
Previous Driving School Vehicle	The Seller must disclose if the vehicle was previously used as a driving school vehicle.	Regular
Previous Emergency Services Vehicle	The Seller must disclose if the vehicle was previously used as an emergency services vehicle.	Regular
Previous Police Vehicle	The Seller must disclose if the vehicle was previously used as a police cruiser.	Regular
Previous Racing Vehicle	The Seller must disclose if the Vehicle was previously used in organized racing.	Regular
Previous Taxi/Limo	The Seller must disclose if the vehicle was previously used as a taxi or limousine.	Regular
Stolen and Recovered	The Seller must disclose if a vehicle was recovered after being reported stolen.	Extended
Structural Alteration	The Seller must disclose if there has been an alteration to the Vehicle's structure such as lengthened or shortened frame, modified suspension, snow plow, hitch or fifth wheel.	Regular
Structural Damage	The Seller must declare a vehicle to have structural damage if there has been damage to the structure or a specific structural component of the Vehicle that meets the definition of structural damage set out in Section VIII of the National Auto	Extended

Declaration	Explanation	Arbitration Period
	Auction Association's Arbitration Policy regarding Structural Damage. (See the <i>Standards</i> section on the NAAA website found at <a href="http://www.naaa.com">www.naaa.com</a> )	
Title Branded _____ (brand)	The Seller must disclose if the vehicle's title has been branded in accordance with provincial or state law and must indicate the brand(s) assigned.	Extended
TKU	The Seller must declare a vehicle TKU (true kilometers unknown) if the distance traveled is unknown and there are no reliable records available to verify the odometer reading as of a certain date. When a vehicle is declared TKU, the total distance that a vehicle has been driven is likely substantially higher than the reading shown on the odometer.	Extended
TKU _____ km as of _____ (date)	If the total distance driven is unknown, but based on reliable records, the distance driven as of a certain date is known, the Seller must declare the last known distance and provide the date.	Extended
Total Loss	The Seller must declare if an insurer determined the vehicle was a total loss.	Extended
U.S. Vehicle*	The Seller must declare if the vehicle was ever registered in the United States or manufactured not in compliance with Canadian standards. All U.S. vehicles offered for sale must include a CarProof Verified vehicle history report, or equivalent.	Regular
VIN Plate issues	The Seller must disclose if the original VIN plate (on the driver's side of the dashboard) has been removed, altered or replaced. Vehicles may not be offered for sale unless the original VIN plate is intact or has been replaced in accordance with provincial and federal regulatory requirements.	Regular
Warranty Cancelled	The Seller must disclose if the manufacturer has cancelled the warranty on the Vehicle or has given notice of its intention to do so. Notice of warranty cancellation given after the date of sale is not subject to arbitration.	Regular
Year _____ Make _____ Model _____ Series _____	The Seller must disclose the year, make, model and series (i.e. trim level) of the vehicle as indicated by means of VIN decoding.	Regular

\* BC mandates a seller to disclose if a vehicle was brought to BC for the purposes of resale. If known, this disclosure should also be made. Otherwise, Buyer should review the registration history to determine whether this disclosure is applicable. No arbitration is available regarding this disclosure.

ARBITRATION PERIODS	
<i>Regular</i>	❖ End of business on sale day or as established by local Auction practice. For internet sales, 1 business day after delivery of the vehicle to the Buyer.
<i>Extended</i>	❖ 7 calendar days following the date of sale, or for internet sales, from the date of delivery to the Buyer. If the Buyer was not able to discover the undisclosed declaration through inspection or a reliable third party vehicle history report, the arbitration period may be extended at the discretion of the Auction.

\*\*\*Note regarding "Warranty Cancelled" Disclosure: If the disclosure is noted on the vehicle history report, the applicable arbitration period is "regular"; otherwise, the arbitration period is "extended".

## B. Manheim Supplemental Disclosure Standards

Declaration	Explanation	Arbitration Period
-------------	-------------	--------------------

Sludged engine		Extended
Non-original Engine (not including items replaced under manufacturer warranty)	Applies only to vehicles at least one calendar year old but not more than four calendar years old	Extended
Bio-Hazard vehicles (both cleaned and contaminated)	Seller must disclose any bio-hazard condition as required by applicable law	Extended
Catalytic Converter Missing or Inoperative*		Regular

\*The Arbitration Dollar Threshold does not apply to this disclosure

## Unibody

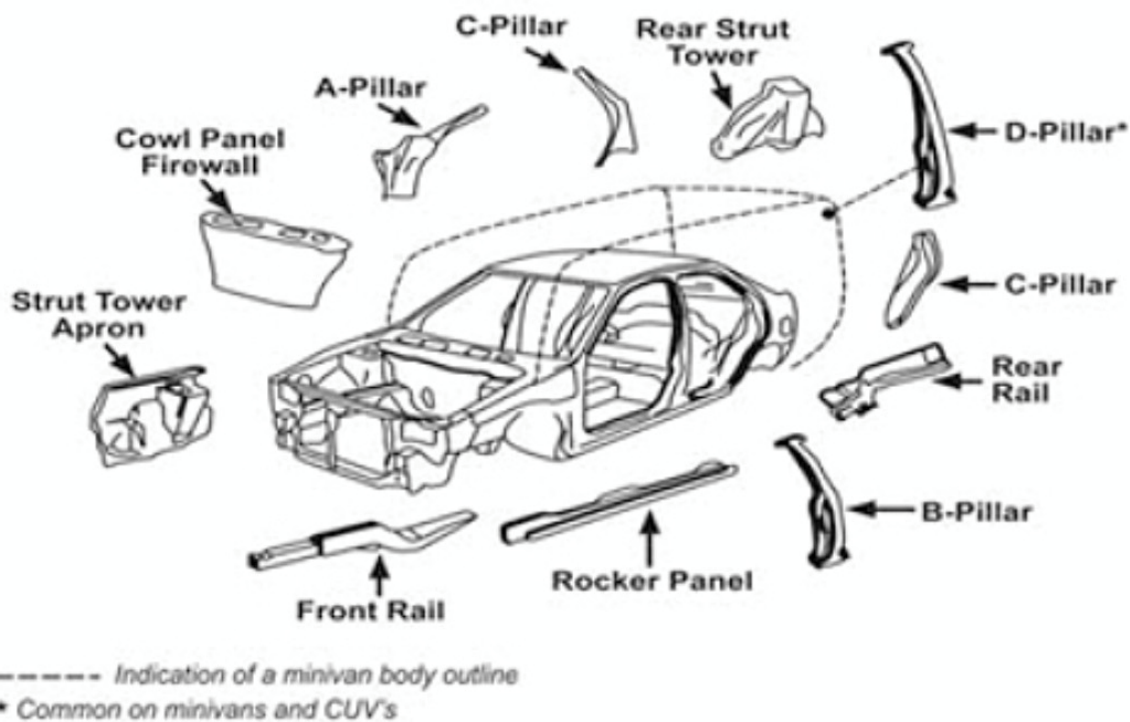

## Unibody on Frame

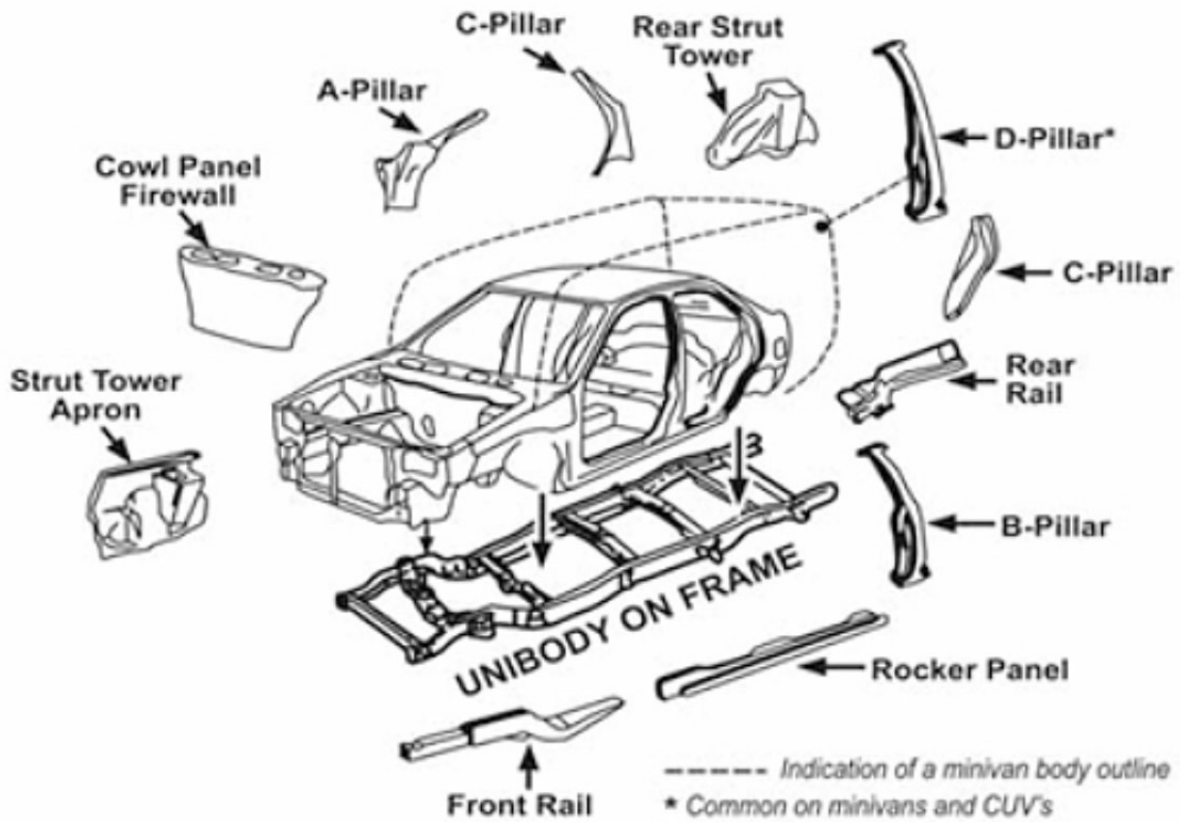

### Conventional Frame Ladder

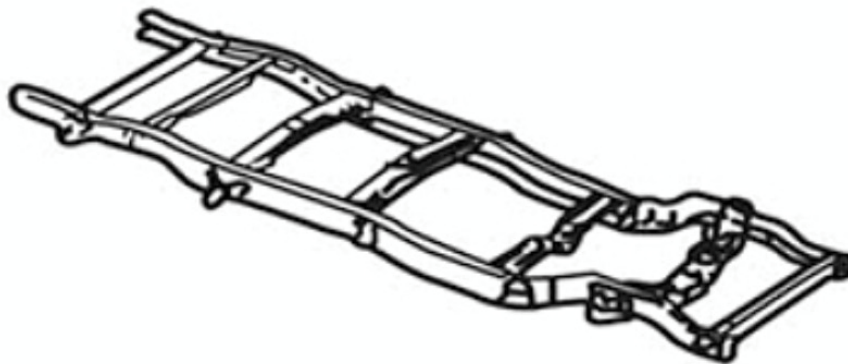

### Conventional Frame Perimeter

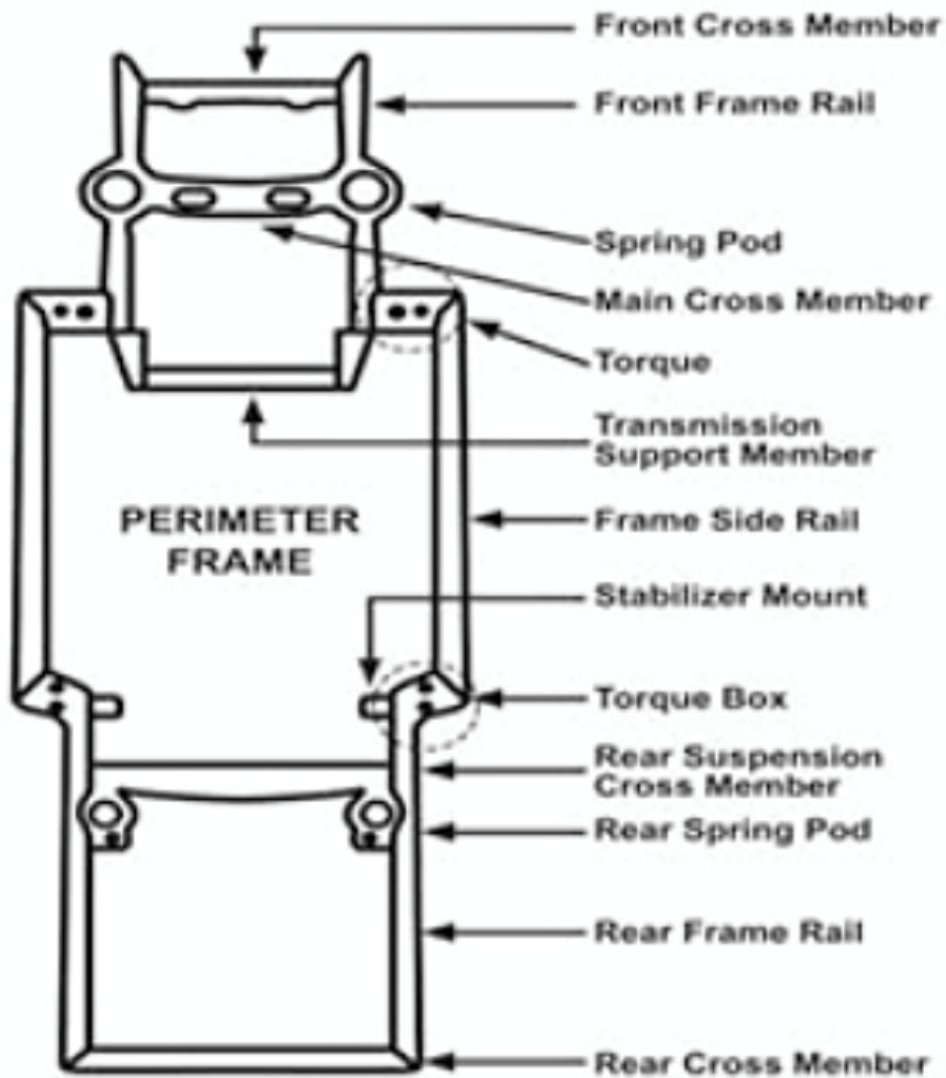

## Frame Identification

Unibody	Unibody on Frame	Co
<ul style="list-style-type: none"> <li>• Strut towers will be present</li> <li>• Rails and floors welded together</li> <li>• No independent rail system</li> <li>• Aprons will be present</li> </ul>	<ul style="list-style-type: none"> <li>• Unibody bolts to frame</li> <li>• Rails independently bolted to suspension and drive train</li> <li>• Has aprons</li> <li>• No strut towers</li> </ul>	<ul style="list-style-type: none"> <li>• Body is</li> <li>• Rails in suspens</li> <li>• No apr</li> <li>• No stru</li> </ul>



<ul style="list-style-type: none"> <li>Core support typically welded to aprons</li> </ul>	<ul style="list-style-type: none"> <li>Rails tend to be thicker gauge metal (iron)</li> <li>Core support typically welded to aprons</li> </ul>	<ul style="list-style-type: none"> <li>Rails tend to be thicker gauge metal (iron)</li> <li>Core support typically welded to aprons</li> </ul>
---	--	--

Component	Disclosure Requirement	
Unibody	Unibody on Frame	Conventional Frame
1. Radiator Core Support - Including the upper and lower tie bars, center support or side baffles	None	
2. Frame Rails Extensions (Ears) - On frame vehicles that area at the end of the frame to which the bumper reinforcement or isolators attach.	None	
3. Frame Rails Including front, center & rear rails	Existing or repaired damage, or replacement	
4. Spring Pod, and Torque Box or Stabilizer Mount	N/A	Existing or repaired damage, or replacement
5. Cross members - Except Bolt-On	N/A	Existing or repaired damage, or replacement
6. Apron/Upper Reinforcement Rails	Existing or repaired damage, or replacement	
7. Strut Tower	Existing or repaired damage, or replacement	
8. Cowl Panel / Firewall - excluding cowl vent panel	Existing or repaired damage, or replacement	
9. Support Pillars - "A," "B," "C" or "D" Pillars	Existing or repaired damage, or replacement	

10. Roof	Replacement
11. Rocker Panel - Outer	Replacements
12. Rocker Panel - Inner	Existing or repaired damage, or replacement
13. Floor Panels	Torn and/or perforated If 1" or more, dented If deflected more than 2" or replacement floor panel
14. Quarter or Cab Panel	Replacement
15. Rear Body Panel	None